

TECHNICAL DATA

GAMAFLOR STRUCTURE ATH / VF

**PEDESTAL ATH / VF**

**1 BASE ATH**

Composed of a square steel plate measuring 127x127mm and 3mm thickness, the base has 4 holes to drain excess of adhesive or allow mechanical anchoring. The centre of the plate is welded a tube with notch and threaded.

**2 HEAD VF**

Composed of a square steel plate measuring 76x76mm and 3mm thickness, 8 holes allow the stringers and/or panels screwing in place. The centre of the plate is linear welded to a threaded steel rod M-18 of variable height.

**3 NUTS**

The M-18 rod is provided with 2 Din-439 nuts of galvanized steel. These nuts work as support, leveling and lock assembly at selected height.

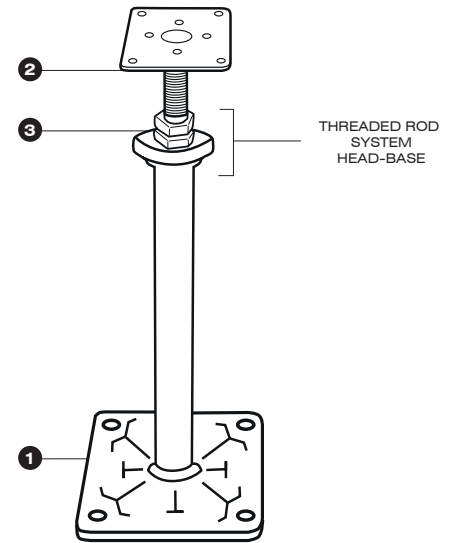

**RANGE STRUCTURE**

	FREE HEIGHTS		
	HL. MIN	HL. MAX	
ATH 800 / VF 260	820	980	<b>FIRE CLASSIFICATION A1</b> Classified by official laboratory melting level of steel 1400 -1500°C
ATH 800 / VF 390	820	1090	
ATH 800 / VF 450	820	1150	
ATH 900 / VF 260	920	1080	<b>VERTICAL LOAD</b> >60 kN
ATH 900 / VF 390	920	1190	
ATH 900 / VF 450	920	1250	
ATH 1200 / VF 260	1220	1360	<b>PROTECTION CORROSION</b> Galvanized
ATH 1200 / VF 390	1220	1490	
ATH 1200 / VF 450	1220	1550	
ATH 1500 / VF 260	1520	1660	<b>ELECTRIC RESISTANCE</b> Max. conductivity 2,0 Ohms
ATH 1500 / VF 390	1520	1790	
ATH 1500 / VF 450	1520	1850	

OTHER POSSIBLE COMBINATIONS UNDER REQUIREMENT

**STRINGER FS-550**

Galvanized steel stringer 1.0mm thickness with acoustic insulation (vibration), screwed to the pedestal with a FS-45 screw.

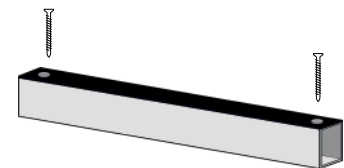

**STRINGER FS-1150**

Galvanized double steel stringer 1.0mm thickness with acoustic insulation (vibration), screwed to the pedestal.

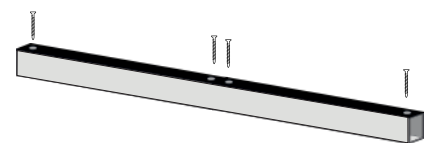

**STRUCTURE FEATURES**

**LEED CERTIFICATION**  
Using this system contributes positively in obtaining LEED certifications, national and international.

**GUARANTEED LEVELLING**  
The structure has a triple screw system that guarantees the leveling of the complete structure.

**SOUND PROOFING**  
This system has acquired acoustic values that improve the reduction of impact noise and acoustic absorption.

**SEISMIC SAFETY**  
The floor system has anti seismic characteristics, granting the safety of its installation.

**PRODUCTS CERTIFIED BY LABORATORIES**



This company reserves the right to make any changes in their product without prior notice.

**ANTISISMIC OPTION**

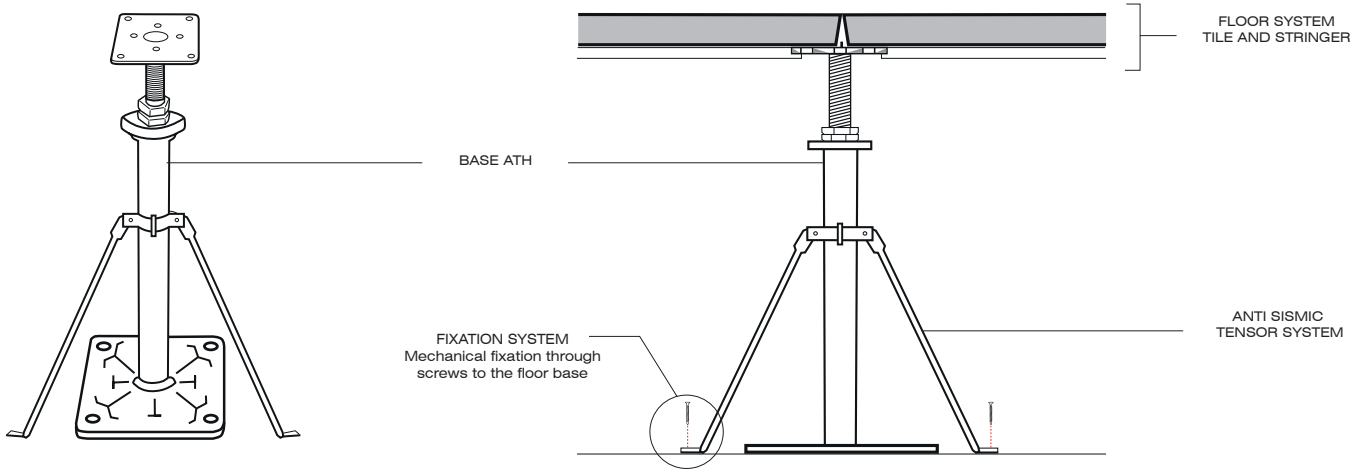

**STRUCTURE WITH STRINGER**

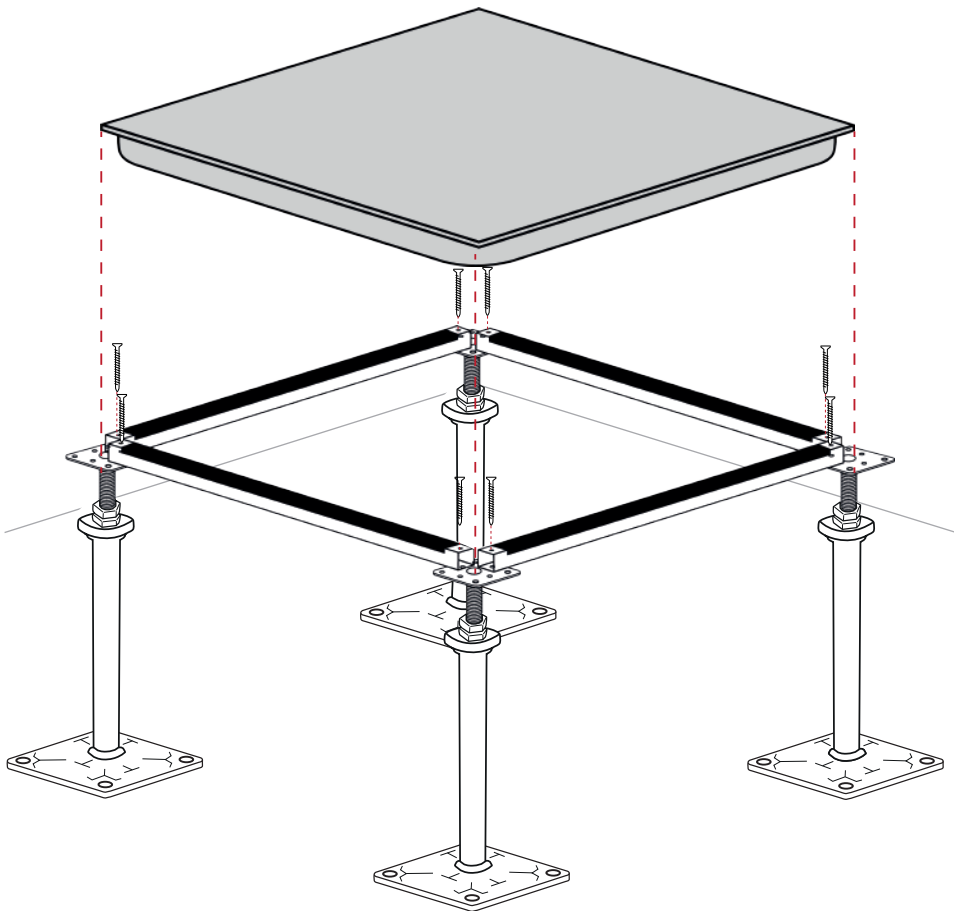

Each tile is supported by a steel structure-pedestal and screwed stringers with different heights so it is possible to access to the space under the floor, that can be used for electric installations, water pipelines, air conditioning, etc.

The election of pedestals depends on necessary maximum and minimum heights (see pedestal ranges).

The fixation of the pedestal to the floor base will be made with adhesive recommended by the manufacturer. Additionally, the pedestal has the possibility of being mechanically fixed with screws, if required by the client.