

INSTRUCCIONES DE MONTAJE ASSEMBLY INSTRUCTIONS INSTRUCCIONS DE MONTAGE

puerta corredera · sliding door · porte coulissante

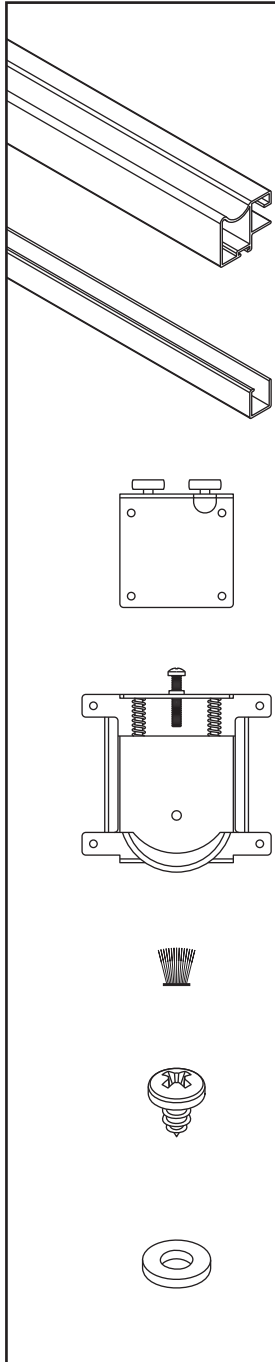

A 2x

tirador
vertical profile
profil vertical
(2,6 m)

B 2x

perfil "U" horizontal
"U" horizontal profile
profil "U" horizontal
(1 m)

C 2x

rueda superior
top wheel
roulette haute

D 2x

rueda inferior
bottom wheel
roulette basse

E 2x

cepillo trasero
inner brush
joint brosse
(2,6 m)

F 1x

bolsa de tornillos
screws bag
sac de vis

G 4x

arandela (solo serie minimal)
washer (only for the minimal series)
rondelle (série minimal seulement)

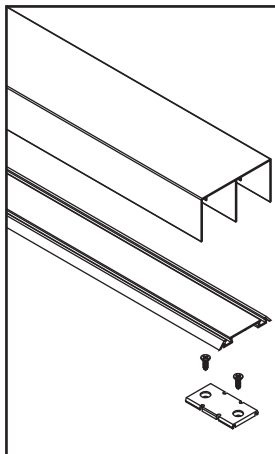
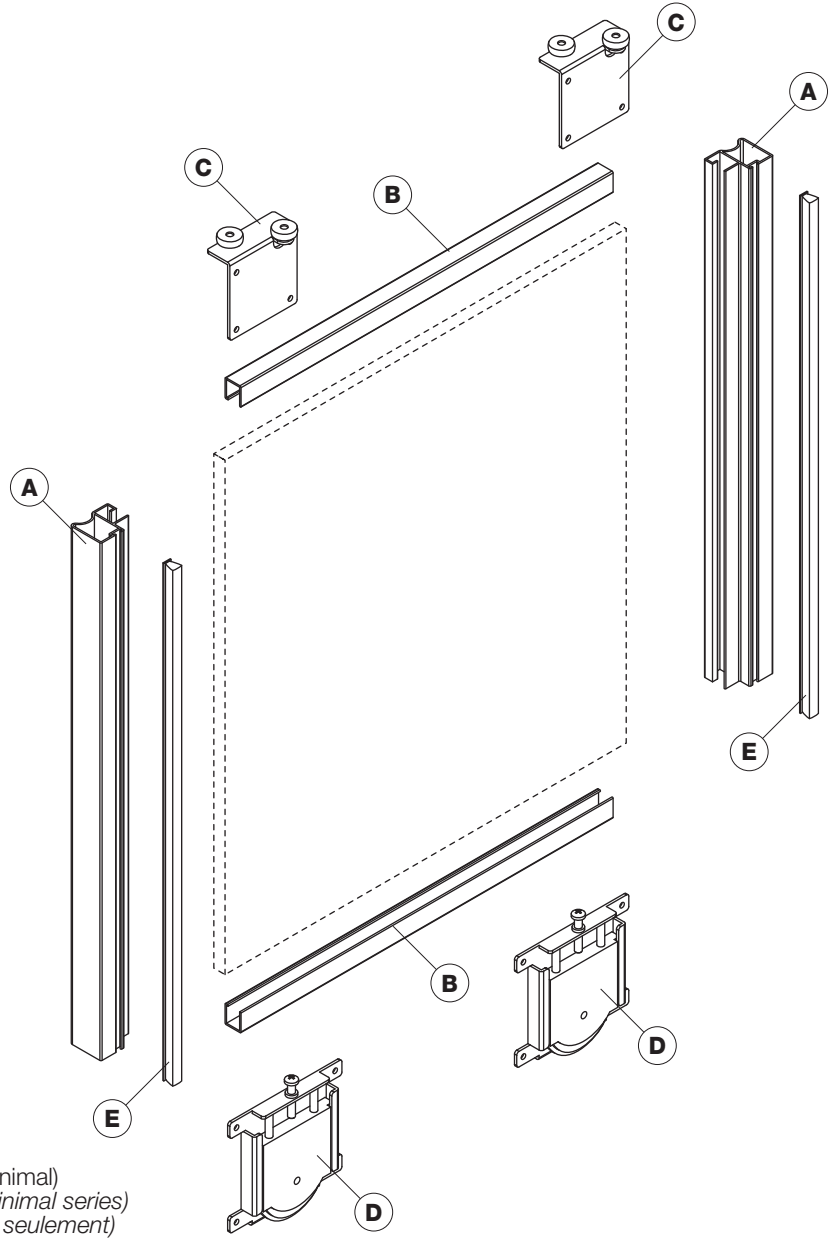

guías · tracks · rails

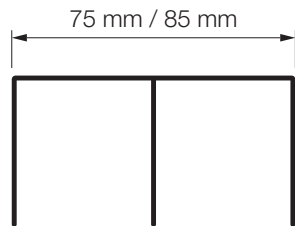

carril alto
top track
rail supérieur



carril bajo
bottom track
rail inférieur

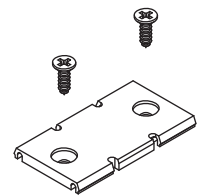

anclaje carril bajo
bottom track fitting
attache rail inférieur

configuración del frente de armario wardrobe front configuration configuration de la façade du placard

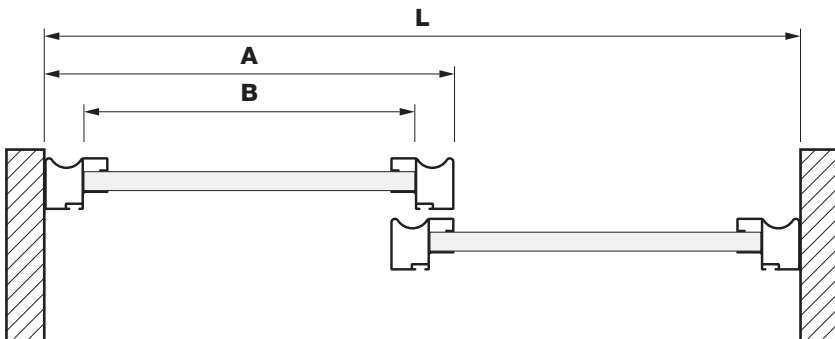
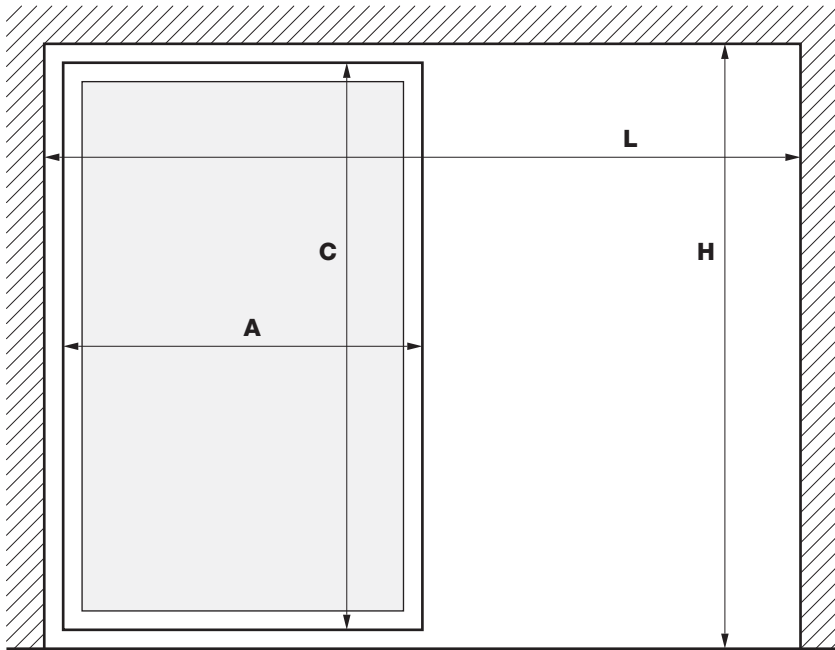

- L** ancho de armario · wardrobe width · largeur du placard
- H** alto de armario · wardrobe height · hauteur du placard
- A** ancho de puerta · door width · largeur de la porte
- C** alto de puerta · door height · hauteur de la porte
- B** ancho de tablero · board width · largeur du panneau
- D** alto de tablero · board height · hauteur du panneau

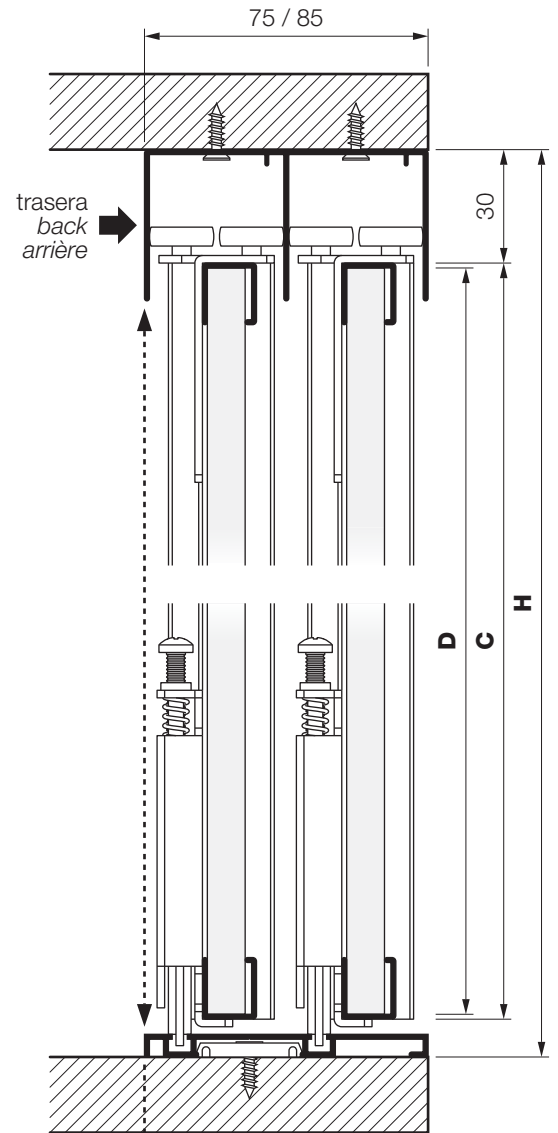

← ← alineación trasera
rear alignment
alignement arrière

← frente
front
avant

montaje carril bajo · bottom track assembly · ensemble rail inférieur		
CBD50 (111500***)		X = 24,5 mm
CBR50 (113500***)		X = 25 mm
CBD60 (511500***)		X = 25 mm

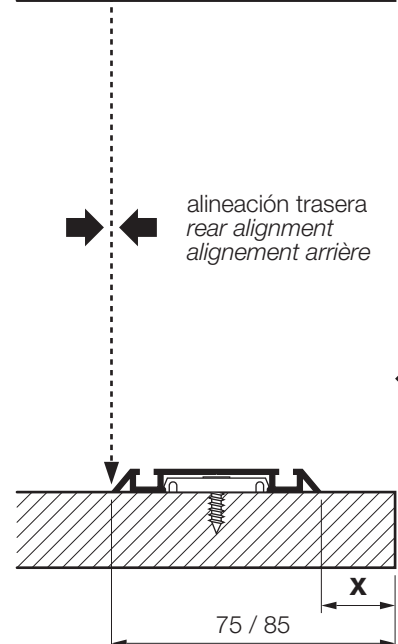

montaje de puertas doors assembly assemblage de portes

- 1** montaje de tiradores
handle profiles assembly
ensemble de profils verticaux

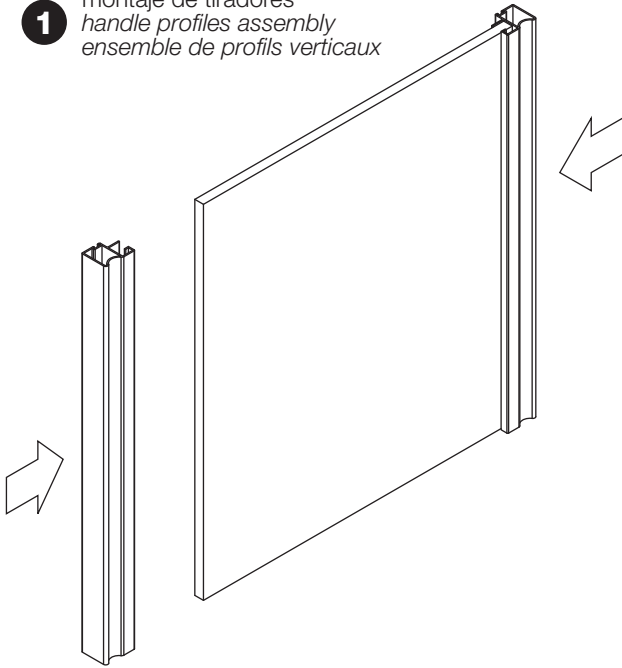

- 2** montaje de perfiles "U" horizontales
"U" horizontal profiles assembly
ensemble de profils "U" horizontaux

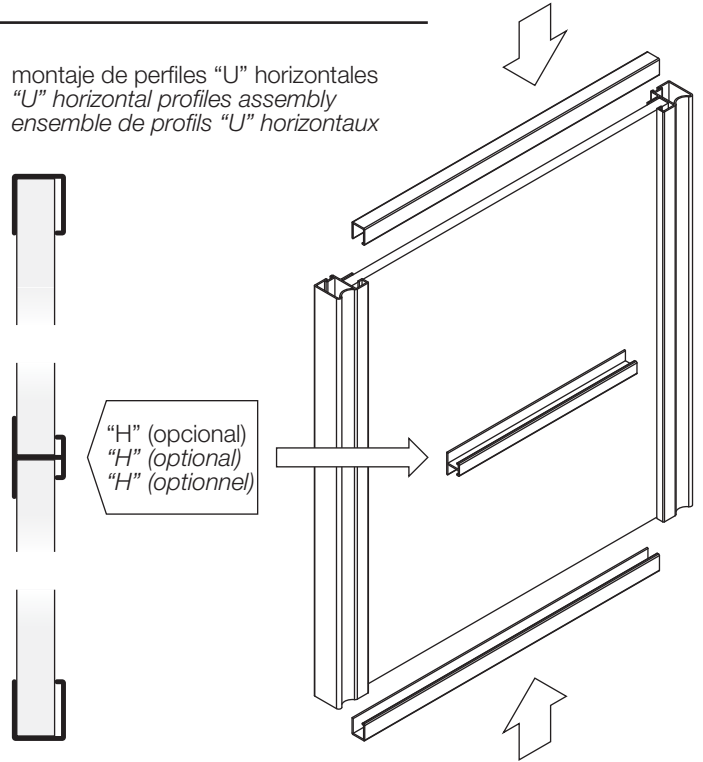

- 3** montaje de ruedas superiores e inferiores
top and bottom wheels assembly
ensemble de roues supérieures et inférieures

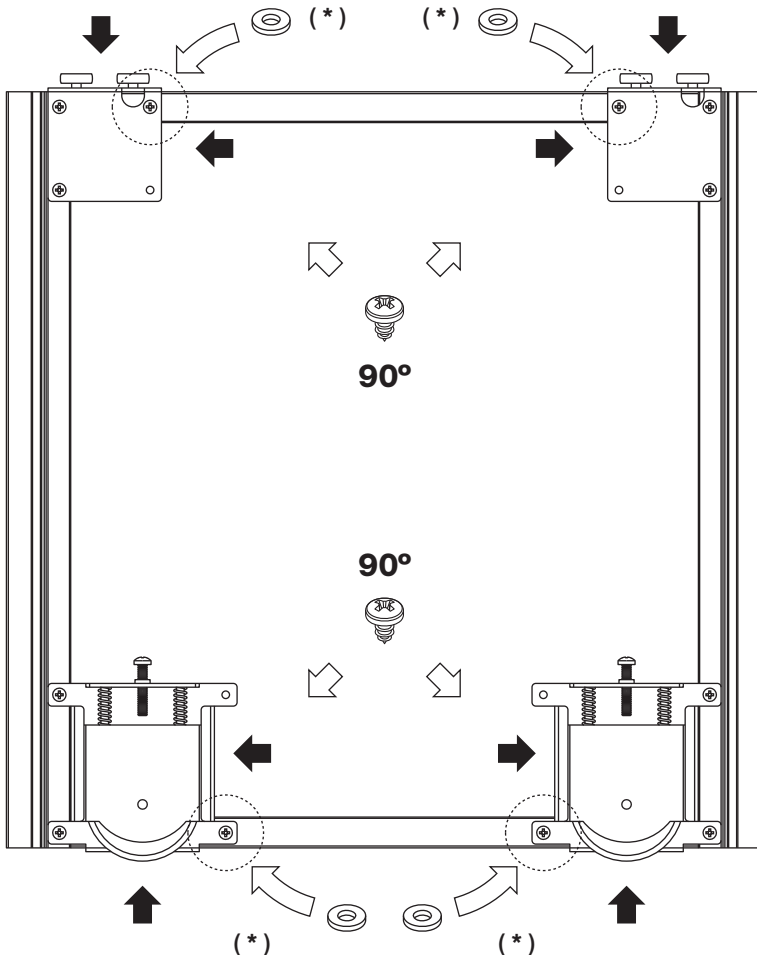

- 4** montaje de puerta de cristal
door glass assembly
ensemble de porte en verre

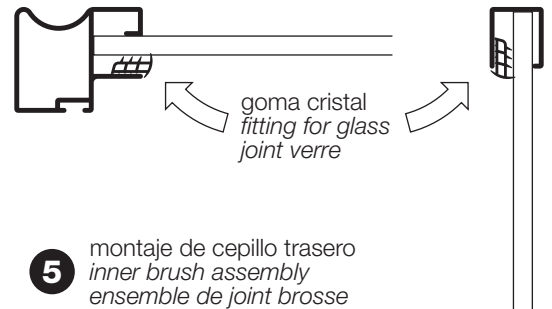

- 5** montaje de cepillo trasero
inner brush assembly
ensemble de joint brosse

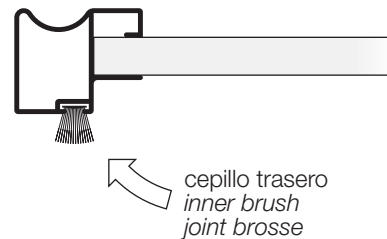

*** IMPORTANTE:**

Utilice las arandelas de separación "G" SOLAMENTE en los perfiles de la **Serie Minimal**.

*** IMPORTANT NOTICE:**

Use the "G" spacers **ONLY** for the following **Minimal Series** profiles.

*** IMPORTANT:**

Utilisez les rondelles de séparation "G" seulement sur les profils de la **Série Minimal**.

instalación de carriles y puertas tracks and doors installation installation de rails et des portes

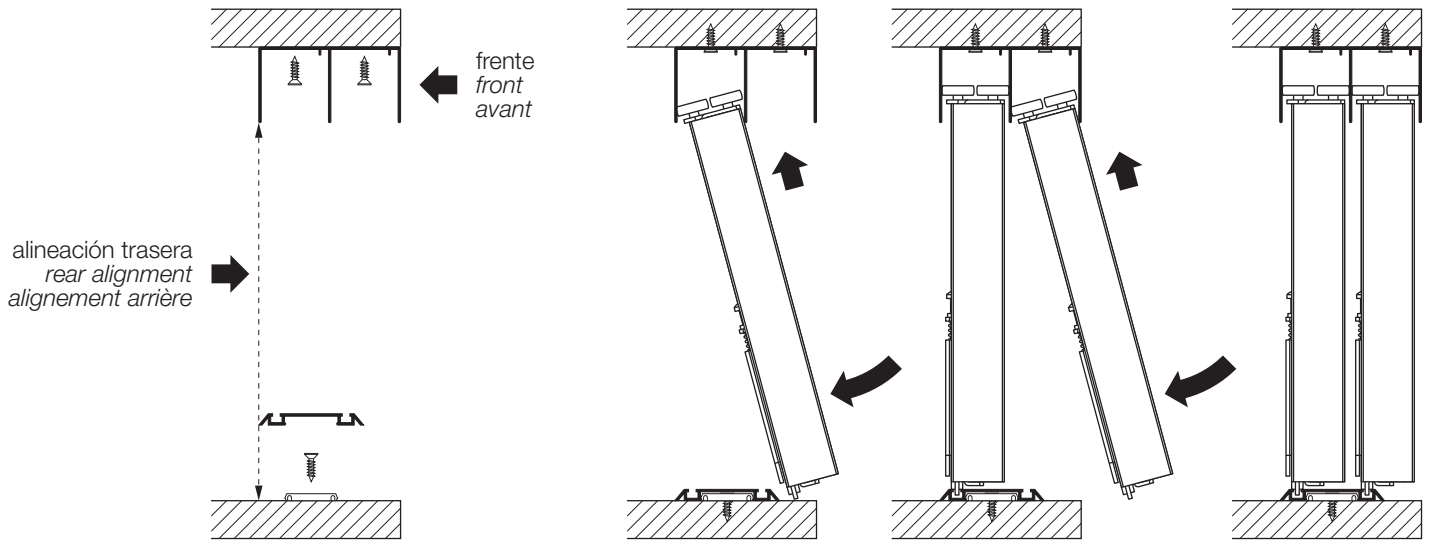

6 colocación de carriles
tracks placement
placement de rails

7 instalación de puertas en el frente de armario
doors installation in wardrobe front
installation de portes au façade du placard

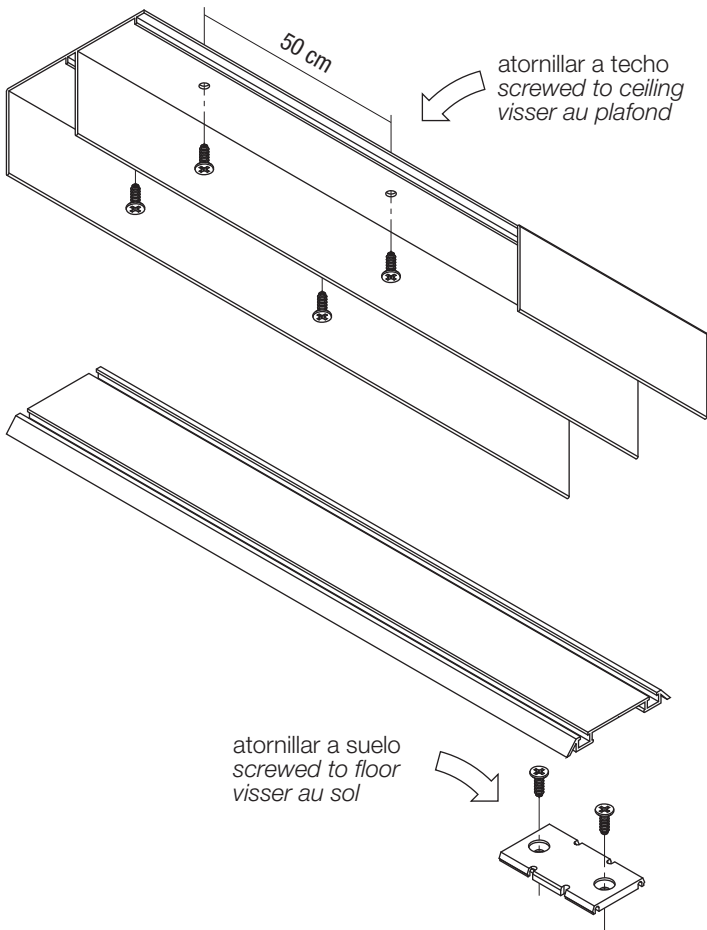

8 regulación en altura de la puerta para su nivelación
height adjustment for leveling the door
réglage en hauteur de la porte pour son niveau

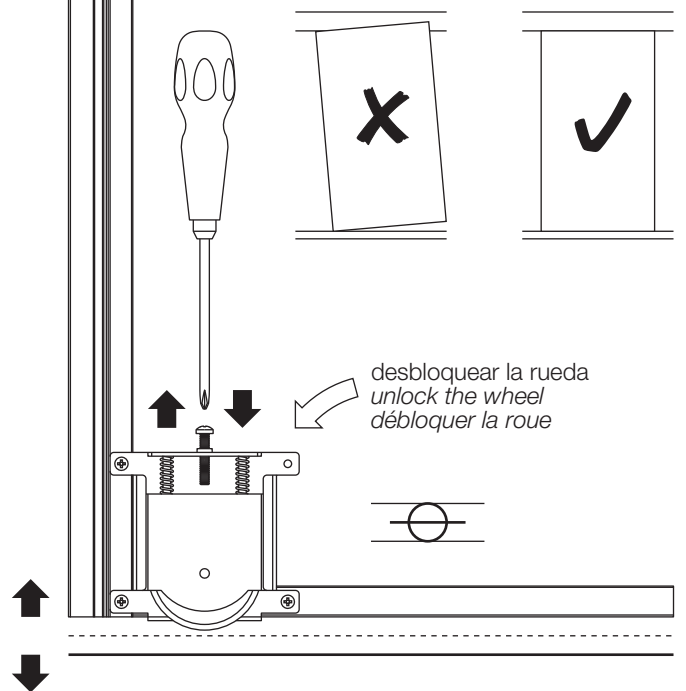

cálculo de corte de perfiles y tableros profiles and panels measurement calculation calcul de découpage de profils et des panneaux

alto de puerta · door height · hauteur de la porte

CBD50
111500***

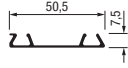

$$C = H - 40 \text{ mm}$$

CBD60
511500***

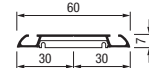

$$C = H - 41 \text{ mm}$$

CBD75
112500***



$$C = H - 44 \text{ mm}$$

CBD85
512500***

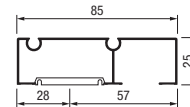

$$C = H - 59 \text{ mm}$$

CBE16
116500***

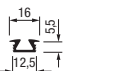

$$C = H - 35 \text{ mm}$$

CBD85-10
513500***

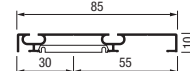

$$C = H - 44 \text{ mm}$$

CBR50
113500***

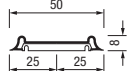

$$C = H - 43 \text{ mm}$$

H alto de armario · wardrobe height · hauteur du placard

C alto de puerta · door height · hauteur de la porte

D alto de tablero · board height · hauteur du panneau

$$D = C - 3 \text{ mm}$$

CBR75
114500***

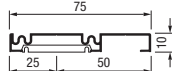

$$C = H - 44 \text{ mm}$$

ancho de puerta · door width · largeur de la porte

classic 33

2 puertas · doors · portes

3 puertas · doors · portes

4 puertas · doors · portes

TR10
140260***

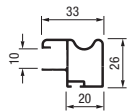

$$A = \frac{L}{2} + 16,5 \text{ mm}$$

$$A = \frac{L}{3} + 22 \text{ mm}$$

$$A = \frac{L}{4} + 16,5 \text{ mm}$$

$$B = \frac{L}{2} - 23,5 \text{ mm}$$

$$B = \frac{L}{3} - 18 \text{ mm}$$

$$B = \frac{L}{4} - 23,5 \text{ mm}$$

classic 34

2 puertas · doors · portes

3 puertas · doors · portes

4 puertas · doors · portes

$$A = \frac{L}{2} + 17 \text{ mm}$$

$$A = \frac{L}{3} + 22,5 \text{ mm}$$

$$A = \frac{L}{4} + 17 \text{ mm}$$

$$B = \frac{L}{2} - 25 \text{ mm}$$

$$B = \frac{L}{3} - 19,5 \text{ mm}$$

$$B = \frac{L}{4} - 25 \text{ mm}$$

TR10CS
160260***

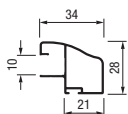

TR10KB
161260***

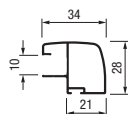

TR16
150260***

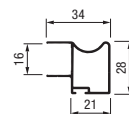

TR16-S85
550260***

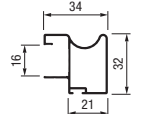

L ancho de armario · wardrobe width · largeur du placard

A ancho de puerta · door width · largeur de la porte

B ancho de tablero · board width · largeur du panneau

ancho de puerta · door width · largeur de la porte

classic 44

2 puertas · doors · portes

3 puertas · doors · portes

4 puertas · doors · portes

$$A = \frac{L}{2} + 22 \text{ mm}$$

$$B = \frac{L}{2} - 40 \text{ mm}$$

$$+ \text{🪪} B - 4 \text{ mm}$$

$$A = \frac{L}{3} + 29,5 \text{ mm}$$

$$B = \frac{L}{3} - 32,5 \text{ mm}$$

$$+ \text{🪪} B - 3 \text{ mm}$$

$$A = \frac{L}{4} + 22 \text{ mm}$$

$$B = \frac{L}{4} - 40 \text{ mm}$$

$$+ \text{🪪} B - 4 \text{ mm}$$

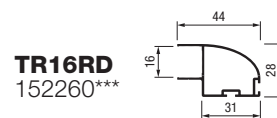
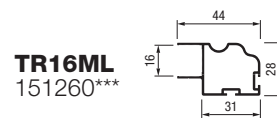

max-60

2 puertas · doors · portes

3 puertas · doors · portes

4 puertas · doors · portes

$$A = \frac{L}{2} + 30 \text{ mm}$$

$$B = \frac{L}{2} - 50 \text{ mm}$$

$$A = \frac{L}{3} + 40 \text{ mm}$$

$$B = \frac{L}{3} - 40 \text{ mm}$$

$$A = \frac{L}{4} + 30 \text{ mm}$$

$$B = \frac{L}{4} - 50 \text{ mm}$$

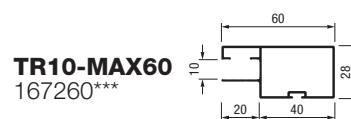

TR19-S85

2 puertas · doors · portes

3 puertas · doors · portes

4 puertas · doors · portes

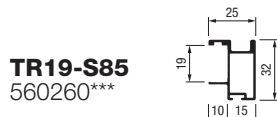

$$A = \frac{L}{2} + 12,5 \text{ mm}$$

$$B = \frac{L}{2} - 17,5 \text{ mm}$$

$$A = \frac{L}{3} + 16,5 \text{ mm}$$

$$B = \frac{L}{3} - 13,5 \text{ mm}$$

$$A = \frac{L}{4} + 12,5 \text{ mm}$$

$$B = \frac{L}{4} - 17,5 \text{ mm}$$

L ancho de armario · wardrobe width · largeur du placard

A ancho de puerta · door width · largeur de la porte

B ancho de tablero · board width · largeur du panneau

cálculo de corte de perfiles y tableros profiles and panels measurement calculation calcul de découpage de profils et des panneaux

ancho de puerta · door width · largeur de la porte

minimal

2 puertas · doors · portes

3 puertas · doors · portes

4 puertas · doors · portes

$$A = \frac{L}{2} + 6 \text{ mm}$$

$$B = \frac{L}{2} + 3,5 \text{ mm}$$

$$A = \frac{L}{3} + 8 \text{ mm}$$

$$B = \frac{L}{3} + 5,5 \text{ mm}$$

$$A = \frac{L}{4} + 6 \text{ mm}$$

$$B = \frac{L}{4} + 3,5 \text{ mm}$$

TR10V1
143260***

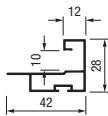

TR10V7
165260***

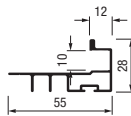

TR16V1-S85
543260***

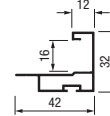

TR16V7-S85
547260***

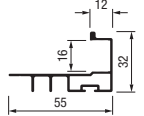

minimal

2 puertas · doors · portes

3 puertas · doors · portes

4 puertas · doors · portes

$$A = \frac{L}{2} + 9 \text{ mm}$$

$$B = \frac{L}{2} - 5,5 \text{ mm}$$

$$A = \frac{L}{3} + 12 \text{ mm}$$

$$B = \frac{L}{3} - 2,5 \text{ mm}$$

$$A = \frac{L}{4} + 9 \text{ mm}$$

$$B = \frac{L}{4} - 5,5 \text{ mm}$$

TR10V2
144260***

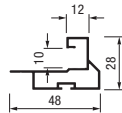

TR16V2-S85
544260***

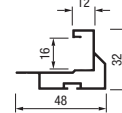

minimal

2 puertas · doors · portes

3 puertas · doors · portes

4 puertas · doors · portes

TR10V4-S85
546260***

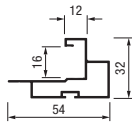

$$A = \frac{L}{2} + 12 \text{ mm}$$

$$B = \frac{L}{2} - 14,5 \text{ mm}$$

$$A = \frac{L}{3} + 16 \text{ mm}$$

$$B = \frac{L}{3} - 10,5 \text{ mm}$$

$$A = \frac{L}{4} + 12 \text{ mm}$$

$$B = \frac{L}{4} - 14,5 \text{ mm}$$

L ancho de armario · wardrobe width · largeur du placard

A ancho de puerta · door width · largeur de la porte

B ancho de tablero · board width · largeur du panneau

cálculo de corte de perfiles y tableros profiles and panels measurement calculation calcul de découpage de profils et des panneaux

ancho de puerta · door width · largeur de la porte

TR min

2 puertas · doors · portes

3 puertas · doors · portes

4 puertas · doors · portes

$$A = \frac{L}{2} + 12,5 \text{ mm}$$

$$B = \frac{L}{2} - 17,5 \text{ mm}$$

$$A = \frac{L}{3} + 16,5 \text{ mm}$$

$$B = \frac{L}{3} - 13,5 \text{ mm}$$

$$A = \frac{L}{4} + 12,5 \text{ mm}$$

$$B = \frac{L}{4} - 17,5 \text{ mm}$$

TR10MIN
14M260***

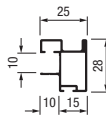

TR16MIN
15M260***

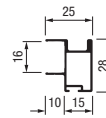

TR16MINS85
55M260***

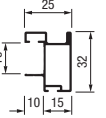

L ancho de armario · wardrobe width · largeur du placard

A ancho de puerta · door width · largeur de la porte

B ancho de tablero · board width · largeur du panneau